

Bell Housing

Cast Steel, Green Sand Casting

Case: A steel bell housing casting of overall size 600 mm x 550 mm x 150 mm weighing 55 kg was produced by sand casting process. This casting suffered from cracks in the inside rim region, discovered after machining.

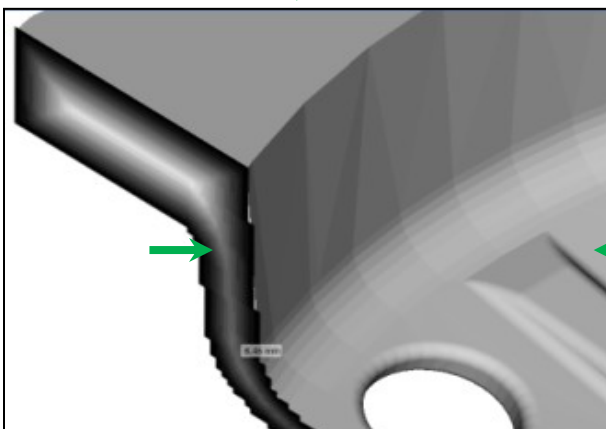
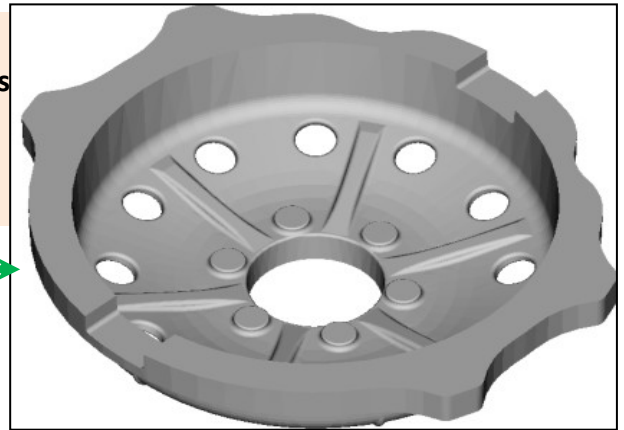
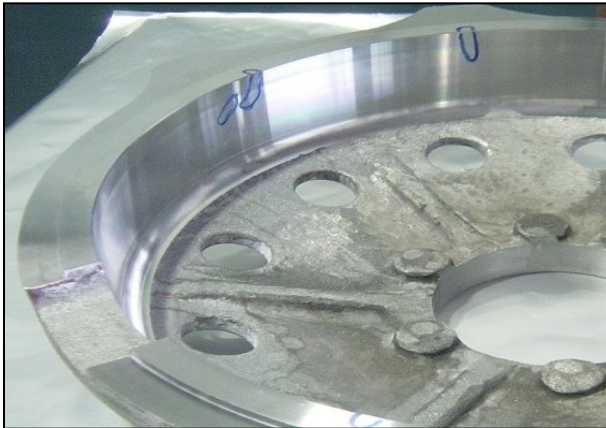

Thickness analysis of the part in a cross section through the ear portion of the rim clearly shows a L-junction with a rapid change of thickness, which is a major cause for stress concentration.

The original methods design included 8 top feeders on the rim, in two different sizes with 4 feeder of each size and a large central feeder. All feeders are provided with insulating sleeves .

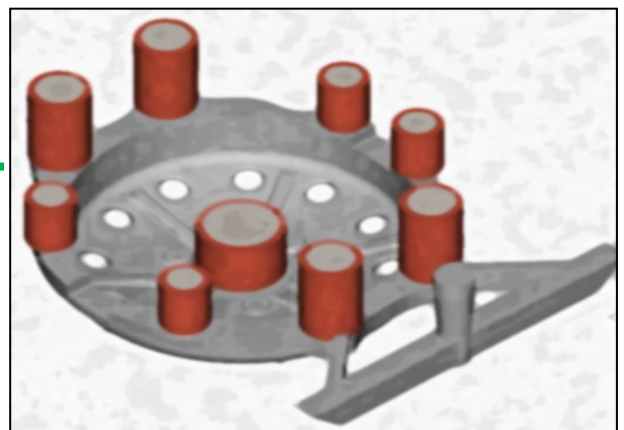

Simulation of original layout shows that the rim area has high temperature owing to the feeder, and also high temperature gradient where the thickness changes.

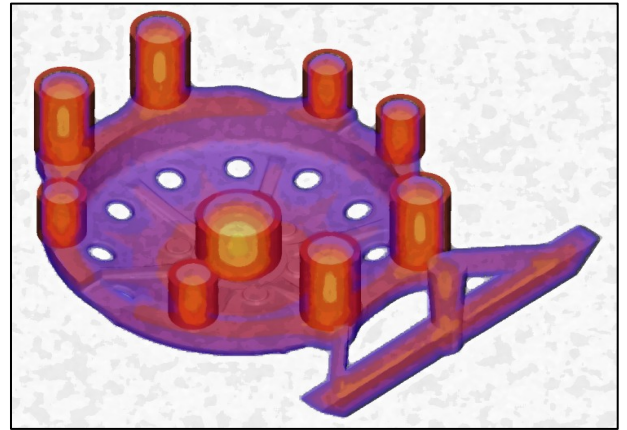
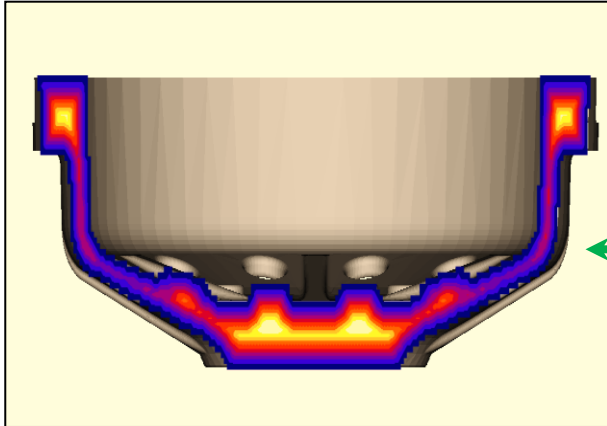

3D modelling and simulation indicate all conditions that lead to cracks:

1. High thickness gradient in the part
2. Constraint from central core portion
3. High temperatures in the rim

Solidification temp analysis shows reduced temperature gradient in the rim section, as section near to rim is with low temperature.

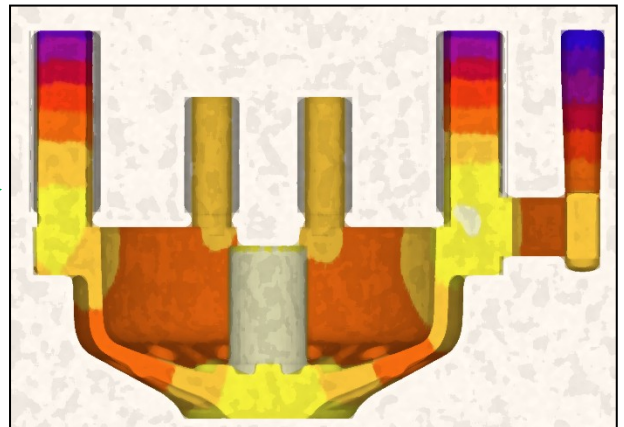
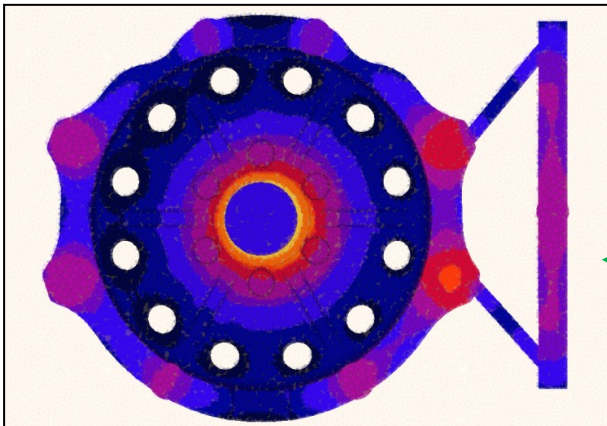

Solidification time analysis also shows rim section also shows variation in cooling rates as section near to ring solidifies at faster rate compared to ring section which induced stress at the ring section.

Thermocouple analysis also reveals that section nearer to rim solidifies faster while rim remains at high temperature for longer time.

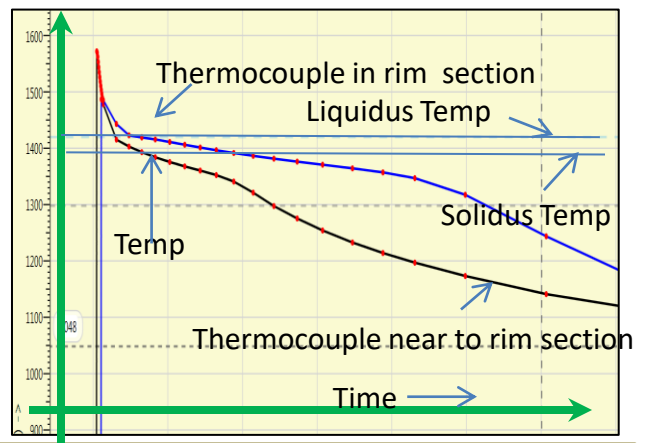

Bell Housing

Cast Steel, Green Sand Casting

In revised methoding layout, four top feeders in the affected area are replaced with side feeders of 60 mm diameter and 100 mm height.

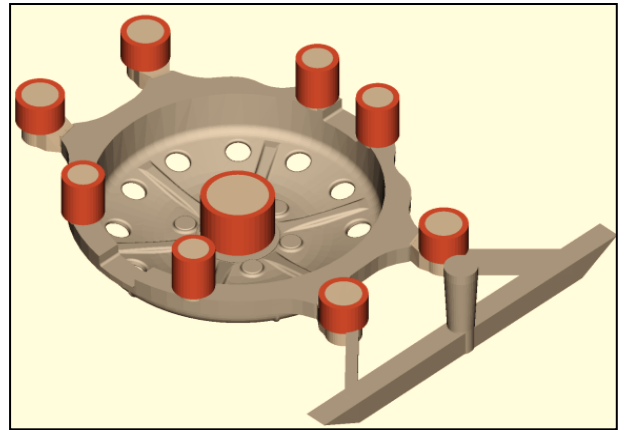
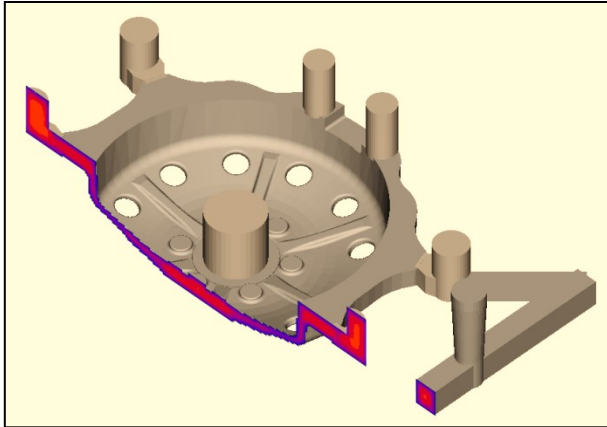

Simulation shows relatively less temperature as well as gradients, reducing hot te

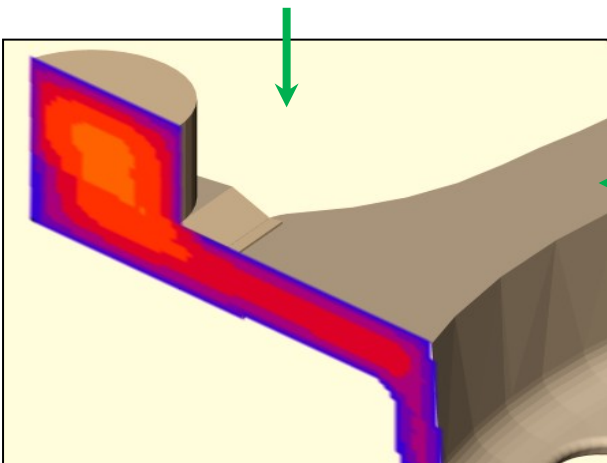

Improved thermal gradient are clearly observed in rim and its nearby sections. The high temperature isolation shifted inside the feeders so rim section is relatively at lower temperature, this leads to stress-free casting with no cracks.

In this figure complete temperature gradient distribution analyzed which shows minimum variation in temperature at thin regions thus no stress will be generated.

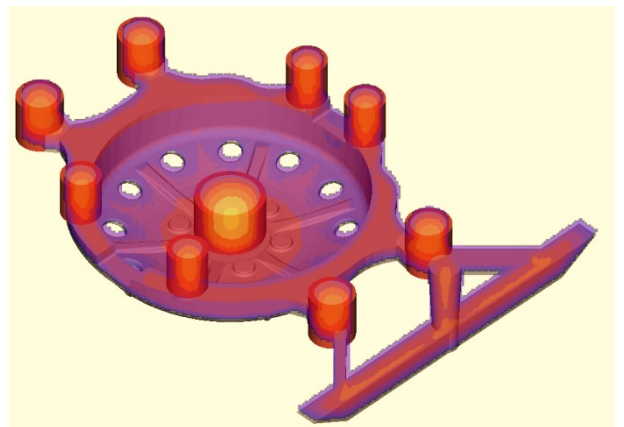

Bell Housing

Cast Steel, Green Sand Casting

Feedpath analysis shows all feedpaths leading to risers. In rim and its near by section found to have controlled progressive directional solidification.

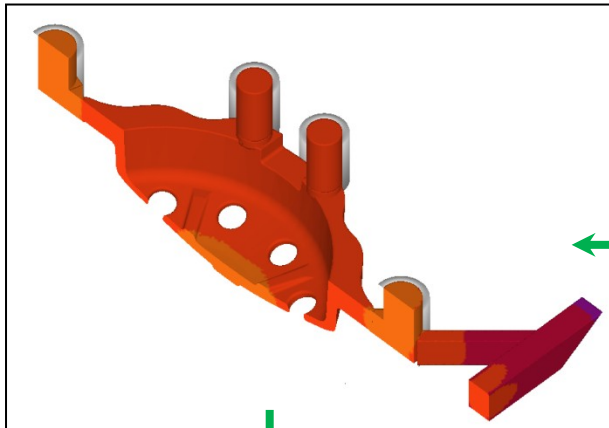
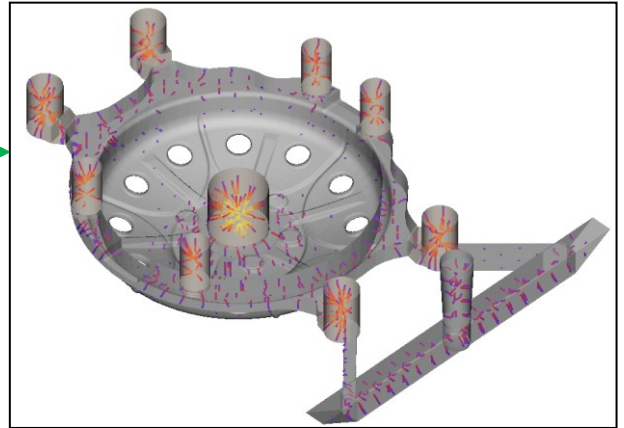

Solidification temperature analysis shows reduced temperature gradients in rim as well as its near by thin section. This results into reduced hot tear defect .

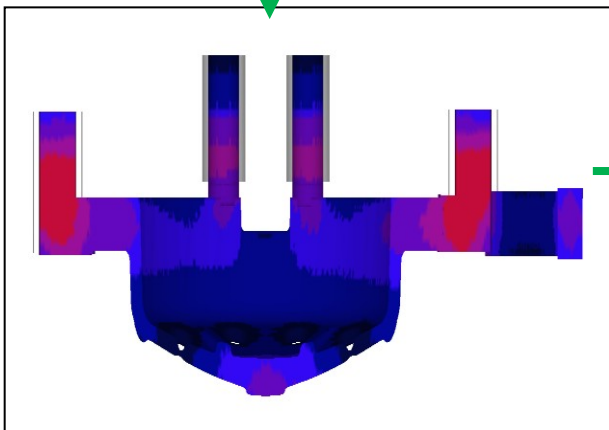

Solidification time analysis shows controlled temperature solidification with no critical variation in solidification time .this controlled solidification reduced hot tear by 50%, further reduction is possible by part design modification to reduce thickness gradient.

Thermocouple analysis suggests that temperature gradients are decreased which effectively reduces the stresses generated in rim section.

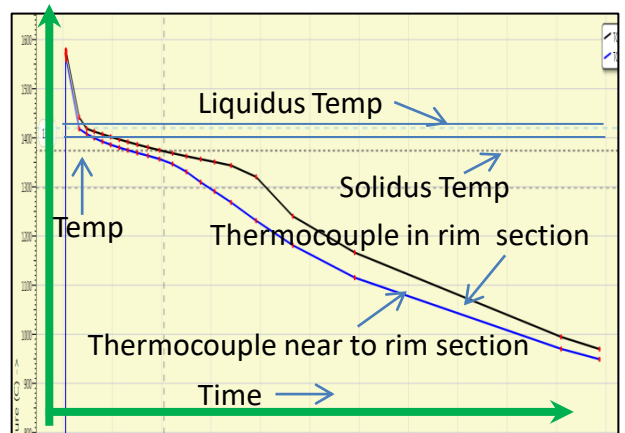

Summary: Replacing the top feeders with side feeders reduced the temperature gradients and thereby hot tears.